

# EASY EPR

EasyEPR is a packaging consultancy business which targets SMEs in Singapore. We aspire to help our clients comply with existing EPR regulations and to better manage their packaging waste.

## Problem

- Extended Producer Responsibility (EPR) is mandated and enforced by the government in 2021
- Companies don't know what to expect or what to do for EPR/ Mandatory Packaging Report (MPR)
- Generally, companies do not want to spend too much time and money on it
- Lack of expertise in this area

## Business Model

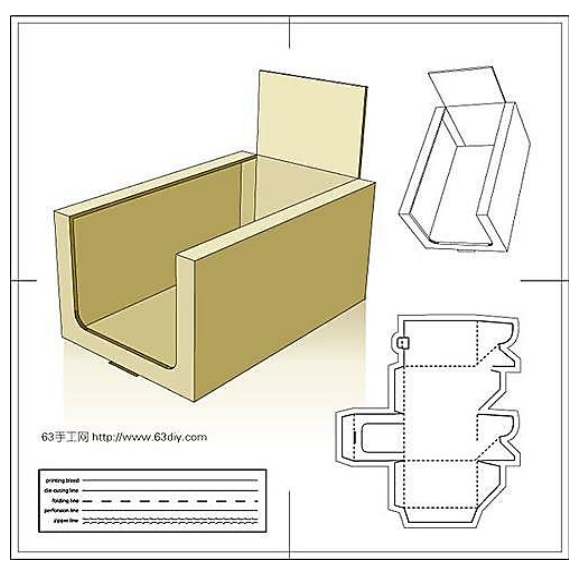

**Redesign**  
\$5000/Project



**Packaging Data**  
\$50/Product



**Promotional Activities**  
\$5000/Project

## Potential Market

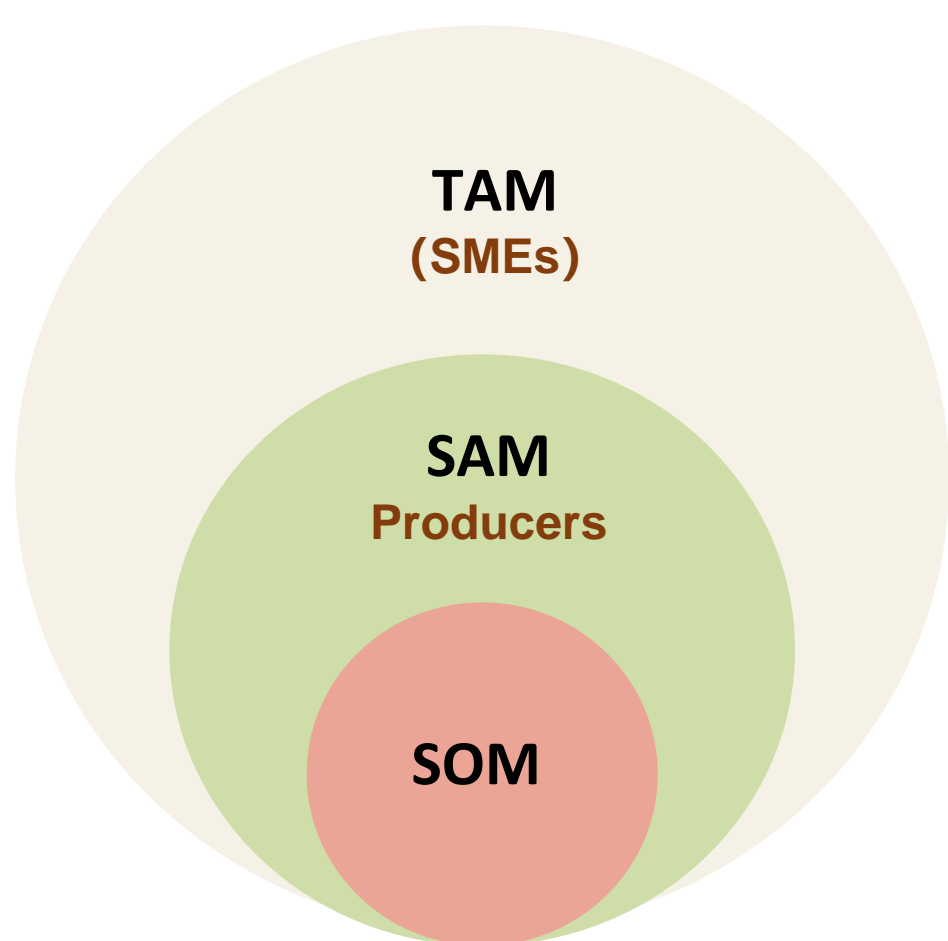

**Singapore market:**

**279700 SMEs (GDP S\$184 Billion (43%))**

**8500 producers (S\$337,799,947)**

**4530 producers in:**

- Textile & Apparels
- Computer & Electronics
- Machinery & Equipment

## 5-year Financial Projection

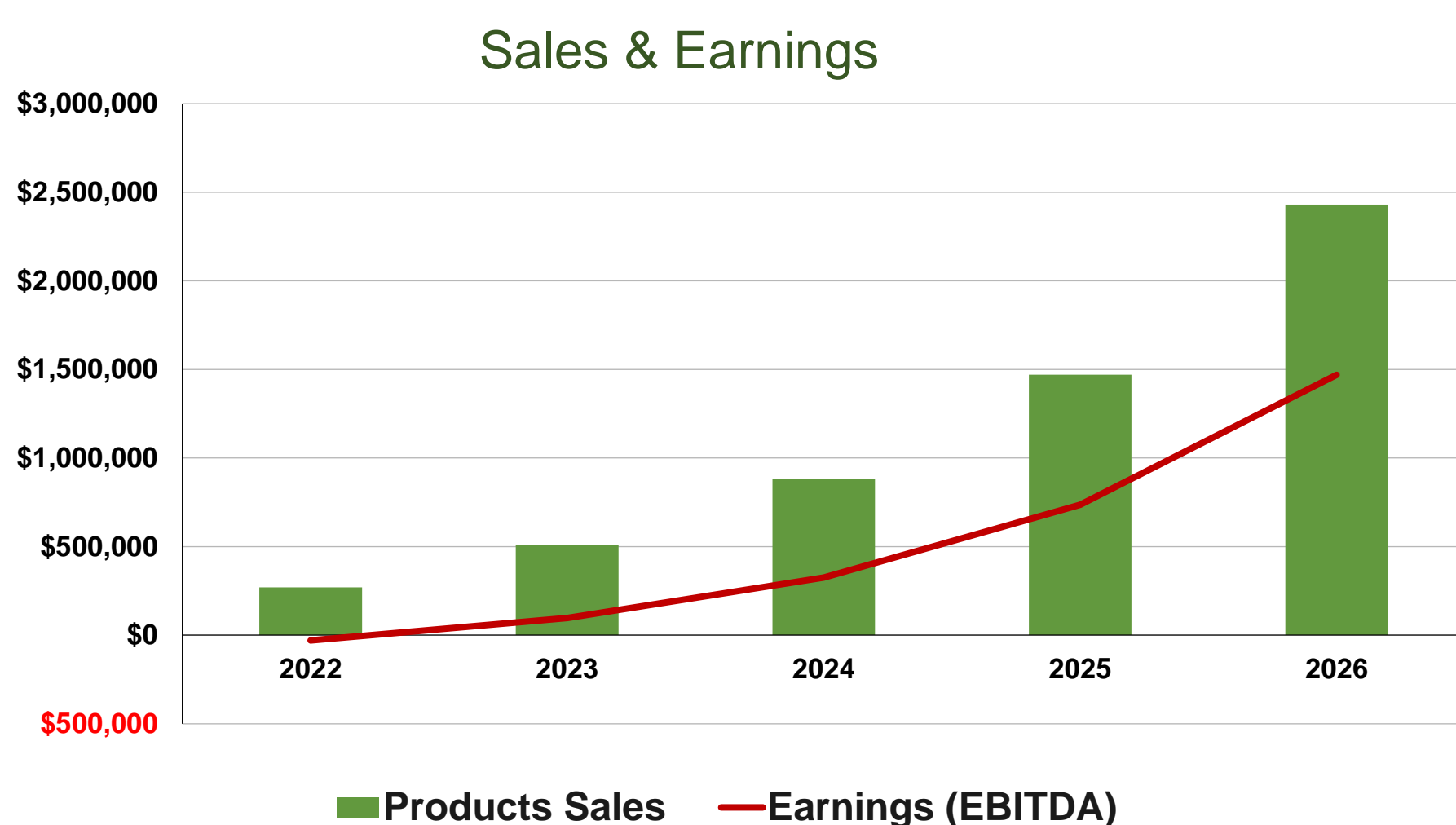

**CAGR 113%** **Year 5 EBITDA \$1,469,565**

## Solution

### 3R Plan Consultation

- Packaging Reduction
- Improve Recyclability
- Promotional Activities

### Quantifying Packaging Data

- For Data Reporting Under MPR Guidelines

### Application for Government Grants

- 3R Funding by NEA

## Development Roadmap

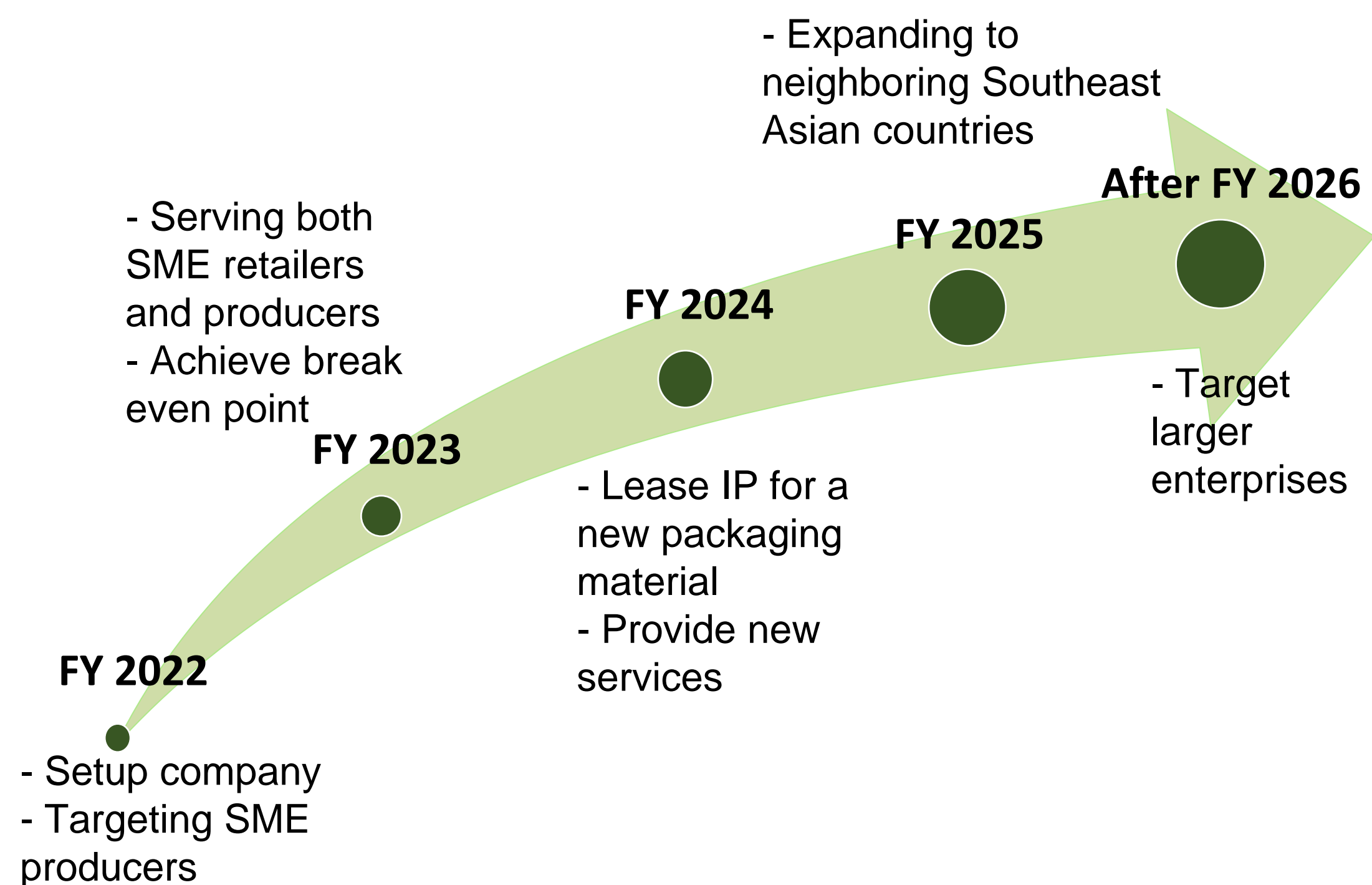

## Go To Market Strategy

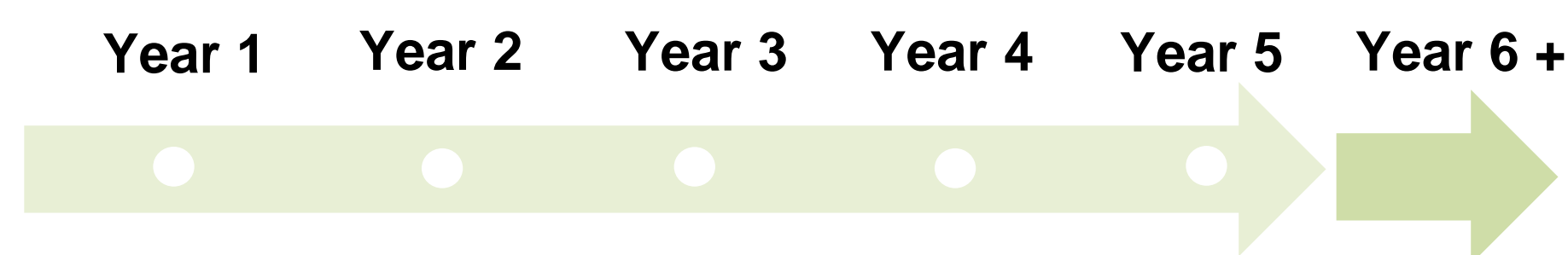

Customers Served	SMEs (Producers)	SMEs (Producers + Retailers)	SMEs	SMEs	SMEs + MNCs	SMEs + MNCs
Regions Served	Singapore	Singapore	Singapore	Southeast Asia	Southeast Asia	Other parts of Asia

## Contact

For more information and business enquiries, contact us at [contact.easyepr@gmail.com](mailto:contact.easyepr@gmail.com) or scan the QR Code at the side --->

